

GENERAL SHELTER SPECIFICATIONS: 8' x 15' Shelter-One Front Opening-Model#TALS815F1-Flat Roof-Full Bench

- A. GENERAL: Unassembled modular shelter is fabricated from low maintenance, lightweight corrosive resistant aluminum (factory fabricated). Site assembly required.
- 1 DIMENSIONS: 7'-6" wide x 15'-0" long, 87'-1/2" exterior height and 83" interior ceiling height.
- 2 FRAME: 6063-T6 aluminum alloy extrusions with Quaker Bronze finish. Framing assembled using internally located mechanical fasteners. Exposed fasteners on framing system are not acceptable. 7 3/4" ventilation space at bottom of unit.
- 3 ROOF/CEILING: Exterior roof shall be constructed using galvanized 20GA, G-60 interlocking pan sections. Sections shall be 3" high with varying widths. Roof shall drain into full perimeter gutter system. Interior ceiling shall be a panel system providing smooth flat interior, constructed from 20GA pre-finished white steel able to support optional lighting.
- 4 WINDOWS: Fixed windows are single pane 1/4" minimum clear tempered safety glass, glazed within wall system extrusions and not fastened to exterior wall. Glass sealed with concealed gasket system.
- 5 ANCHORING: Shelter installation requires concrete pad to be 12" minimum larger than shelter in both length and width dimensions. Pad must be level within 1/2" over length and width of structure. Shelter to be anchored to pad using height adjustable aluminum boot and anchored down using 1/4" X 1 7/8" HILTI KIWK HUS-EZ screw anchors.
- 6 BENCH: (Qty-1) Two-piece anodized aluminum bench system includes aluminum plank bench, plank backrest, end caps, brackets and hardware. Bench to be installed by others in the field.
- INSTALLATION: Unit knocked down and crated, off loaded and installed by others.



Twin Modular Services Inc.
 1001 Lower Landing Rd. Ste 607
 Blackwood, NJ 08012
 PHONE: 856-227-0057
 e-mail:
 info@guardboothonline.com
 www.guardboothonline.com

Notice - Twin Modular Services Inc. claims proprietary rights in the information disclosed on this drawing. It is issued in confidence for engineering information only and may not be used, in whole or in part, to manufacture anything whether or not shown hereon, reproduced or disclosed to anyone without direct written permission from Twin Modular Services Inc.

TITLE:	7'-6" X 15'-0" ALUMINUM SHELTER
JOB NO:	
QUOTE NO:	
LOCATION:	
MOD NO:	TALS815F1
COLOR:	SEE SPECIFICATIONS
DATE:	08.24.22
DRAWN BY:	CDA
SCALE:	N.T.S.
SHEET:	1 OF 2

CUSTOMER APPROVAL

THESE DRAWINGS AND SPECIFICATIONS HAVE BEEN PRODUCED IN ACCORDANCE WITH TWIN MODULAR SERVICES INC. PROPOSAL AND THE PROJECT DESIGN. THE PROJECT WILL BE MANUFACTURED IN ACCORDANCE TO THIS INFORMATION AS SUBMITTED. THE SECURING OF BUILDING PERMITS AND COMPLIANCE WITH APPROPRIATE BUILDING CODES IS THE RESPONSIBILITY OF THE PURCHASER OF THE BUILDING AND NOT THE RESPONSIBILITY OF TWIN MODULAR SERVICES

- APPROVED AS SUBMITTED
- APPROVED AS NOTED
- REVISE AND RESUBMIT

SIGNED: _____ DATE: _____

CERTIFICATION

ELEVATION A

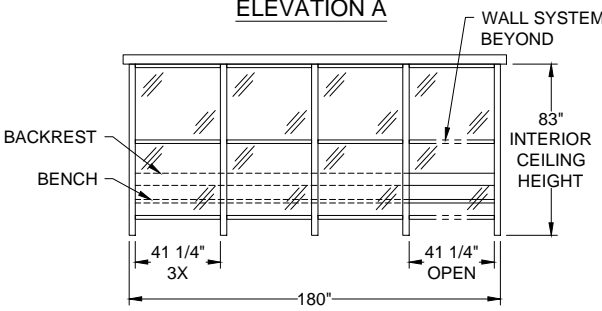

ELEVATION B

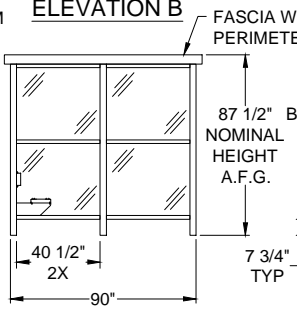

ELEVATION C

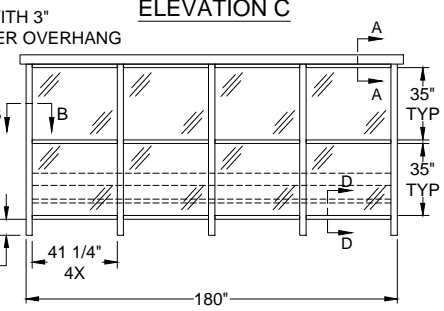

ELEVATION D

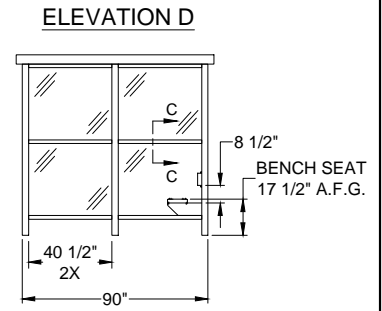

C

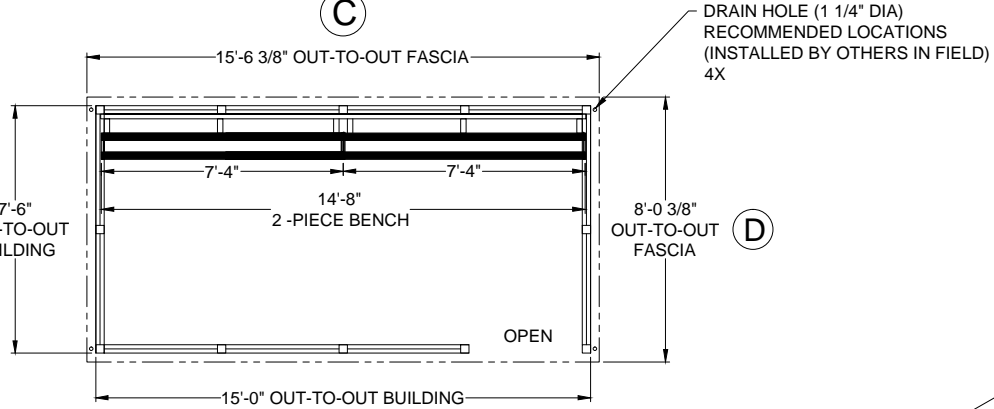

PLAN VIEW

A

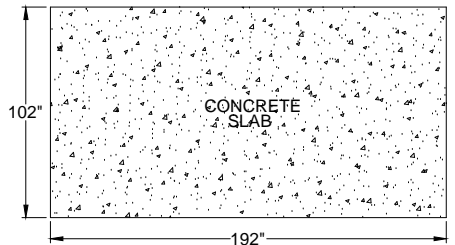

NOTE: CONCRETE SLAB DESIGN BY OTHERS-DIMENSIONS SHOWN ARE RECOMMENDED MINIMUM SIZES ONLY

CUSTOMER APPROVAL

THESE DRAWINGS AND SPECIFICATIONS HAVE BEEN PRODUCED IN ACCORDANCE WITH TWIN MODULAR SERVICES INC. PROPOSAL AND THE PROJECT DESIGN. THE PROJECT WILL BE MANUFACTURED IN ACCORDANCE TO THIS INFORMATION AS SUBMITTED. THE SECURING OF BUILDING PERMITS AND COMPLIANCE WITH APPROPRIATE BUILDING CODES IS THE RESPONSIBILITY OF THE PURCHASER OF THE BUILDING AND NOT THE RESPONSIBILITY OF TWIN MODULAR SERVICES

- APPROVED AS SUBMITTED
- APPROVED AS NOTED
- REVISE AND RESUBMIT

SIGNED: _____ DATE: _____

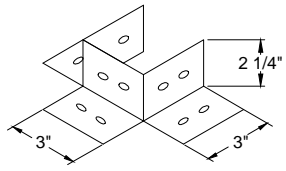

ANCHOR BOOT

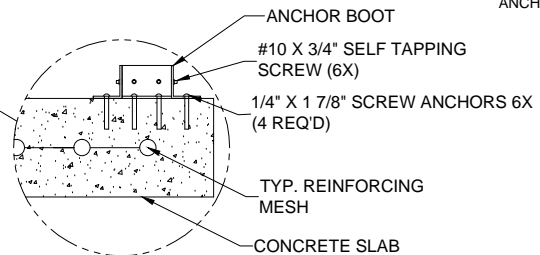

ANCHORING DETAIL

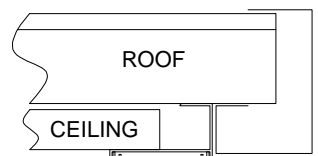

VIEW A-A

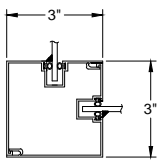

VIEW B-B

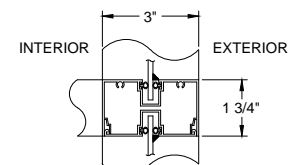

VIEW C-C

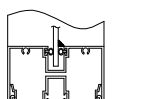

VIEW D-D

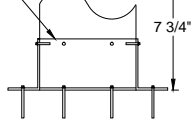

CERTIFICATION



Twin Modular Services Inc.
 1001 Lower Landing Rd. Ste 607
 Blackwood, NJ 08012
 PHONE: 856-227-0057
 e-mail:
 info@guardboothonline.com
 www.guardboothonline.com

Notice - Twin Modular Services Inc. claims proprietary rights in the information disclosed on this drawing. It is issued in confidence for engineering information only and may not be used, in whole or in part, to manufacture anything whether or not shown hereon, reproduced or disclosed to anyone without direct written permission from Twin Modular Services Inc.

TITLE:	7'-6" X 15'-0" ALUMINUM SHELTER
JOB NO:	
QUOTE NO:	
LOCATION:	
MOD NO:	TALS815F1
COLOR:	SEE SPECIFICATIONS
DATE:	08.24.22
DRAWN BY:	CDA
SCALE:	N.T.S.
SHEET:	2 OF 2