

GENERAL SHELTER SPECIFICATIONS: 5' X 10'-MODEL#TALS510F2-FLAT ROOF-TWO(2) FRONT OPENINGS-ADA BENCH

- A. GENERAL: Unassembled modular shelter is fabricated from low maintenance, lightweight corrosive resistant aluminum (factory fabricated). Site assembly required.
- 1 DIMENSIONS: 5'-0" wide x 10'-0" long, 87 1/2" nominal exterior height and 83" interior ceiling height.
- 2 FRAME: Provide structural framing of 6063-T6 aluminum alloy extrusions with Quaker Bronze finish. Framing assembled using internally located mechanical fasteners. Exposed fasteners on framing system are not acceptable. Standard 7 3/4" ventilation space at bottom of unit. **Two Front Openings**
- 3 ROOF/CEILING: Roof shall be constructed using galvanized 20 gauge, G-60 interlocking pan sections. Sections are 3" high varying widths. Roof drains into full perimeter gutter system with drain holes. Interior ceiling shall be a panel system providing smooth flat interior, constructed from 20 gauge prefinished white steel able to support optional lighting or heating fixtures.
- 4 WINDOWS: Fixed windows are single pane 1/4" minimum clear tempered safety glass, glazed within wall system extrusions and not fastened to exterior wall. Glass sealed with concealed gasket system.
- 5 ANCHORING: Shelter installation requires concrete pad to be 12" minimum larger than shelter in both length and width dimensions. Pad must be level within 1/2" over length and width of structure. Shelter to be anchored to pad using height adjustable aluminum shoe and anchored down using 1/4" X 1 7/8" Hilti Kwik Hus-EZ screw anchors. Concrete pad by others in the field.

Optional Bench: ADA Length- approx. 6'- aluminum with support brackets

INSTALLATION: Unit is knocked down and crated, off loaded and installed by-others.

TWIN MODULAR SERVICES INC
 1001 LOWER LANDING ROAD STE 607
 BLACKWOOD, NJ 08012



Twin Modular Services Inc.
 1001 Lower Landing Rd. Ste 607
 Blackwood, NJ. 08012
 Ph: 856-227-0057
 e-mail: info@guardboothonline.com
 www.guardboothonline.com

Notice - Twin Modular Services Inc. claims proprietary rights in the information disclosed on this drawing. It is issued in confidence for engineering information only and may not be used, in whole or in part, to manufacture anything whether or not shown hereon, reproduced or disclosed to anyone without direct written permission from Twin Modular Services Inc.

TITLE:	5'-0" X 10'-0" ALUMINUM SHELTER
JOB NO:	-
QUOTE NO:	
LOCATION:	- TBD
MOD NO:	TALS510F2
COLOR:	SEE SPECIFICATIONS
DATE:	02.18.20
DRAWN BY:	TMK
SCALE:	N.T.S.
SHEET:	1 OF 2

CUSTOMER APPROVAL

THESE DRAWINGS AND SPECIFICATIONS HAVE BEEN PRODUCED IN ACCORDANCE WITH TWIN MODULAR SERVICES INC. PROPOSAL AND THE PROJECT DESIGN. THE PROJECT WILL BE MANUFACTURED IN ACCORDANCE TO THIS INFORMATION AS SUBMITTED. THE SECURING OF BUILDING PERMITS AND COMPLIANCE WITH APPROPRIATE BUILDING CODES IS THE RESPONSIBILITY OF THE PURCHASER OF THE BUILDING AND NOT THE RESPONSIBILITY OF TWIN MODULAR SERVICES INC.

- APPROVED AS SUBMITTED
- APPROVED AS NOTED
- REVISE AND RESUBMIT

SIGNED: _____ DATE: _____

CERTIFICATION

TWIN MODULAR SERVICES INC
 1001 LOWER LANDING ROAD STE 607
 BLACKWOOD, NJ 08012



Twin Modular Services Inc.
 1001 Lower Landing Rd. Ste 607
 Blackwood, NJ. 08012
 Ph: 856-227-0057
 e-mail: info@guardboothonline.com
 www.guardboothonline.com

Notice - Twin Modular Services Inc. claims proprietary rights in the information disclosed on this drawing. It is issued in confidence for engineering information only and may not be used, in whole or in part, to manufacture anything whether or not shown hereon, reproduced or disclosed to anyone without direct written permission from Twin Modular Services Inc.

TITLE:	5'-0" X 10'-0" ALUMINUM SHELTER
JOB NO:	-
QUOTE NO:	
LOCATION:	- TBD
MOD NO:	TALS510F2
COLOR:	SEE SPECIFICATIONS
DATE:	02.18.20
DRAWN BY:	TMK
SCALE:	N.T.S.
SHEET:	2 OF 2

ELEVATION A

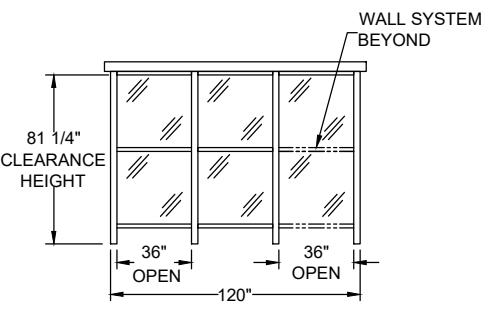

ELEVATION B & D

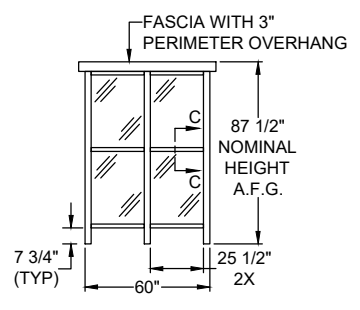

ELEVATION C

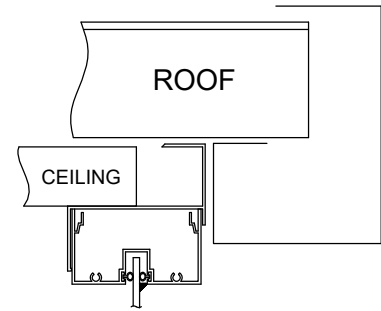
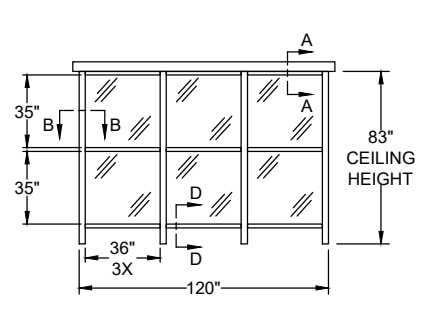

VIEW A-A

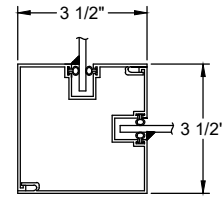

VIEW B-B

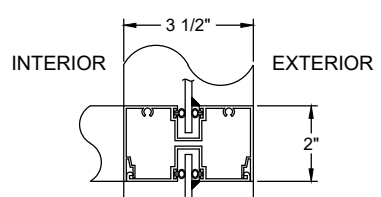

VIEW C-C

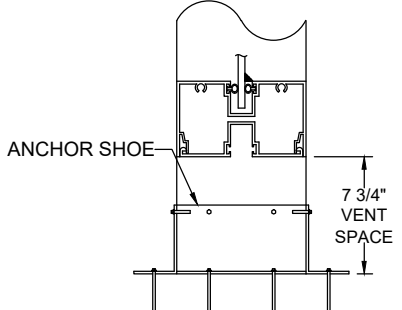

VIEW D-D



Optional-ADA Length Bench-Approx. 6'

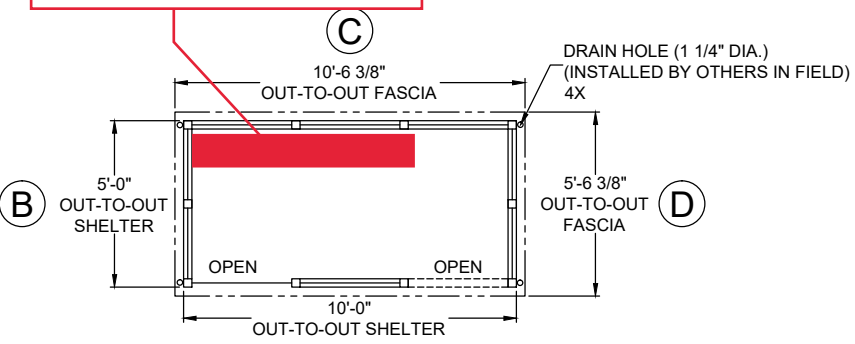

PLAN VIEW

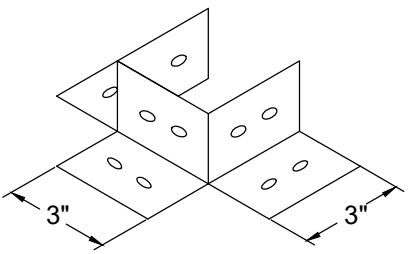

ANCHOR SHOE

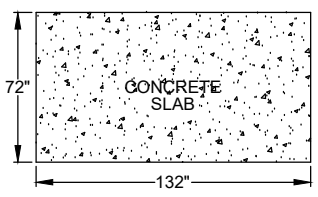

NOTE: CONCRETE SLAB DESIGN BY OTHERS-DIMENSIONS SHOWN ARE RECOMMENDED MIN. SIZES ONLY

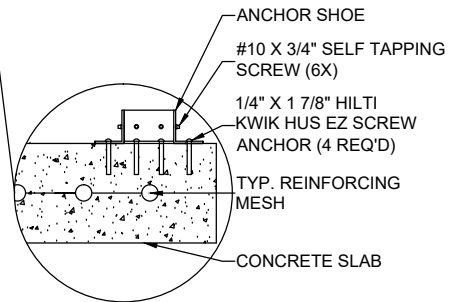

ANCHORING DETAIL

CUSTOMER APPROVAL

THESE DRAWINGS AND SPECIFICATIONS HAVE BEEN PRODUCED IN ACCORDANCE WITH TWIN MODULAR SERVICES INC. PROPOSAL AND THE PROJECT DESIGN. THE PROJECT WILL BE MANUFACTURED IN ACCORDANCE TO THIS INFORMATION AS SUBMITTED. THE SECURING OF BUILDING PERMITS AND COMPLIANCE WITH APPROPRIATE BUILDING CODES IS THE RESPONSIBILITY OF THE PURCHASER OF THE BUILDING AND NOT THE RESPONSIBILITY OF TWIN MODULAR SERVICES INC.

APPROVED AS SUBMITTED
 APPROVED AS NOTED
 REVISE AND RESUBMIT

SIGNED: _____ DATE: _____

CERTIFICATION