

GENERAL SHELTER SPECIFICATIONS: 5' X 15'-TWO(2) FRONT OPENINGS-STANDING SEAM HIP ROOF-MODEL#:TALS515H2

A. GENERAL: Unassembled modular shelter is fabricated from low maintenance, lightweight corrosive resistant aluminum (factory fabricated). Site assembly required.

- 1 DIMENSIONS: 5'-0" wide x 15'-0" long, 102 1/2" nominal exterior height.
- 2 FRAME: Provide structural framing of 6063-T6 aluminum alloy extrusions. Members shall have a Quaker Bronze or Clear Anodized finish. Framing assembled using internally located mechanical fasteners. Exposed fasteners on framing system are not acceptable. Standard 7 3/4" ventilation space at bottom of unit. Two front openings.
- 3 VAULTED HIP ROOF: Vaulted standing seam hip roof shall be constructed using 1/8" aluminum tube frame with 24 GA interlocking pan sections. Sections are 1 1/2" high. Color to be determined from manufacturers standard color selection chart. Roof drains into full perimeter extruded aluminum gutter with 3 3/8" high fascia system. Fascia color to match frame color.
- 4 WINDOWS: Fixed windows are single pane 1/4" clear tempered safety glass, glazed within wall system extrusions and not fastened to exterior wall. Glass sealed with concealed gasket system.
- 5 ANCHORING: Shelter installation requires concrete pad to be 12" minimum larger than shelter in both length and width dimensions. Pad must be level within 1/2" over length and width of structure. Shelter to be anchored to pad using height adjustable aluminum boot and anchored down using 1/4" X 1 7/8" Hilti Kwik Hus-EZ screw anchors.
- 6 BENCH: (Qty-1) Full length (two-piece) anodized aluminum bench system includes aluminum plank bench and aluminum plank backrest, end caps, brackets and hardware. Bench shall be shipped loose, and installed by others in the field.
- INSTALLATION: Unit is knocked down and crated, off loaded and installed by others.



Twin Modular Services Inc.
 1001 Lower Landing Rd. Ste 607
 Blackwood, NJ. 08012
 Ph: 856-227-0057
 e-mail: info@guardboothonline.com
 www.guardboothonline.com

Notice - Twin Modular Services Inc. claims proprietary rights in the information disclosed on this drawing. It is issued in confidence for engineering information only and may not be used, in whole or in part, to manufacture anything whether or not shown hereon, reproduced or disclosed to anyone without direct written permission from Twin Modular Services Inc.

TITLE: 5'-0" x 15'-0"
 ALUMINUM SHELTER

JOB NO:

QUOTE NO:

LOCATION: TBD

MOD NO: TALS515H2

COLOR: SEE SPECIFICATIONS

DATE:

DRAWN BY: JRG

SCALE: N.T.S.

SHEET: 1 OF 2

CUSTOMER APPROVAL

THESE DRAWINGS AND SPECIFICATIONS HAVE BEEN PRODUCED IN ACCORDANCE WITH TWIN MODULAR SERVICES INC. PROPOSAL AND THE PROJECT DESIGN. THE PROJECT WILL BE MANUFACTURED IN ACCORDANCE TO THIS INFORMATION AS SUBMITTED. THE SECURING OF BUILDING PERMITS AND COMPLIANCE WITH APPROPRIATE BUILDING CODES IS THE RESPONSIBILITY OF THE PURCHASER OF THE BUILDING AND NOT THE RESPONSIBILITY OF TWIN MODULAR SERVICES INC.

- APPROVED AS SUBMITTED
 APPROVED AS NOTED
 REVISE AND RESUBMIT

SIGNED: _____ DATE: _____

CERTIFICATION

ELEVATION A

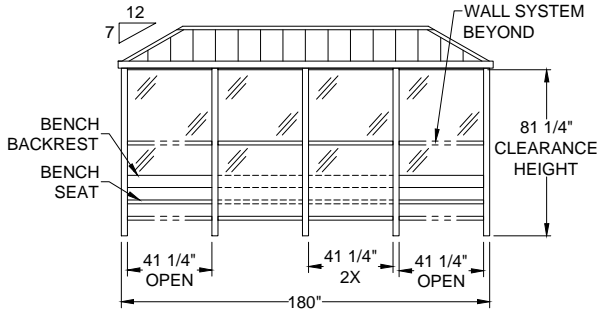

ELEVATION B

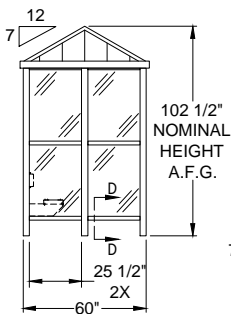

ELEVATION C

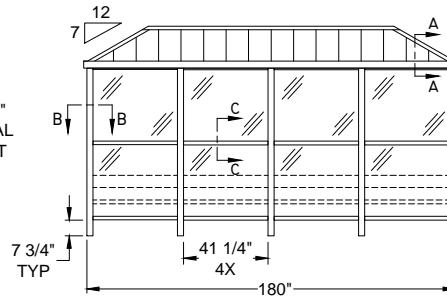

ELEVATION D

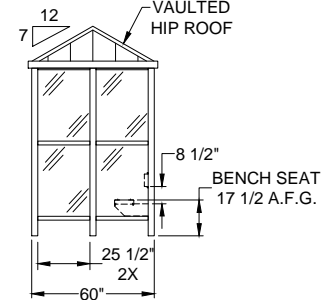

(C)

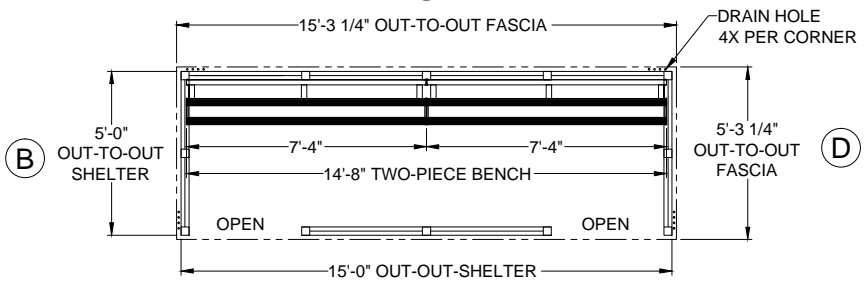

(A)

PLAN VIEW

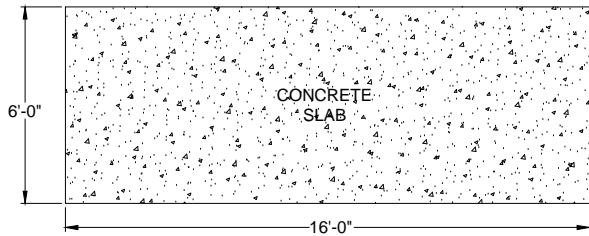

NOTE: CONCRETE SLAB DESIGN BY OTHERS-DIMENSIONS SHOWN ARE RECOMMENDED MIN. SIZES ONLY

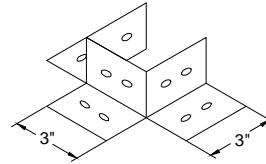

ANCHOR SHOE

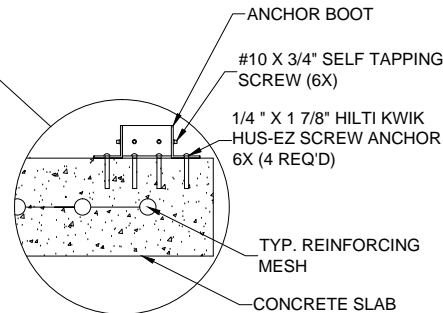

ANCHORING DETAIL

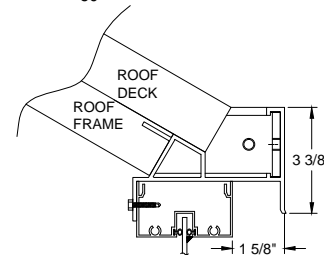

VIEW A-A

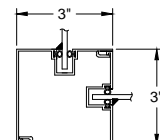

VIEW B-B

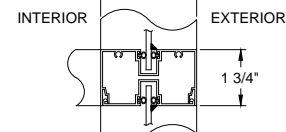

VIEW C-C

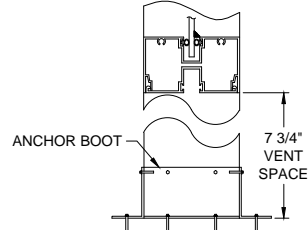

VIEW D-D

CERTIFICATION



Twin Modular Services Inc.
 1001 Lower Landing Rd. Ste 607
 Blackwood, NJ. 08012
 Ph: 856-227-0057
 e-mail: info@guardboothonline.com
 www.guardboothonline.com

Notice - Twin Modular Services Inc. claims proprietary rights in the information disclosed on this drawing. It is issued in confidence for engineering information only and may not be used, in whole or in part, to manufacture anything whether or not shown hereon, reproduced or disclosed to anyone without direct written permission from Twin Modular Services Inc.

TITLE:	5'-0" x 15'-0" ALUMINUM SHELTER
JOB NO:	
QUOTE NO:	
LOCATION:	TBD
MOD NO:	TALS515H2
COLOR:	SEE SPECIFICATIONS
DATE:	
DRAWN BY:	JRG
SCALE:	N.T.S.
SHEET:	2 OF 2

CUSTOMER APPROVAL

THESE DRAWINGS AND SPECIFICATIONS HAVE BEEN PRODUCED IN ACCORDANCE WITH TWIN MODULAR SERVICES INC. PROPOSAL AND THE PROJECT DESIGN. THE PROJECT WILL BE MANUFACTURED IN ACCORDANCE TO THIS INFORMATION AS SUBMITTED. THE SECURING OF BUILDING PERMITS AND COMPLIANCE WITH APPROPRIATE BUILDING CODES IS THE RESPONSIBILITY OF THE PURCHASER OF THE BUILDING AND NOT THE RESPONSIBILITY OF TWIN MODULAR SERVICES INC..

- APPROVED AS SUBMITTED
- APPROVED AS NOTED
- REVISE AND RESUBMIT

SIGNED: _____ DATE: _____