

GENERAL BUILDING SPECIFICATIONS: (QTY - 1 BUILDING)

- A. GENERAL: Pre-assemble building fabricated from low maintenance, lightweight corrosive resistant aluminum (factory fabricated). Building exterior shall have no exposed fasteners.
- 1 DIMENSIONS: 7'-9" wide x 12'-0" long with a 98 1/2" nominal exterior height and 90" interior ceiling height.
 - 2 FRAME CONSTRUCTION: Provide structural framing of 6063-T6 aluminum alloy extrusions. Members shall have a Quaker Bronze, White or Clear Anodized finish. Connections shall be fastened internally to framing systems using mechanical fasteners or MIG welded where necessary. Exposed fasteners on framing system are not acceptable.
 - 3 BASE/FLOOR: Building shall be constructed on a 4" mechanical tube frame encapsulated with a protective undercoating paint. Floor assembly shall be comprised of 1/8" aluminum tread plate finished floor. Forklift pockets shall be provided at 32" center-to-center for lifting.
 - 4 LOWER WALL PANEL: Exterior shall be .032 Quaker Bronze, White or Clear Anodized aluminum, 2 3/4" polyiso insulation (R-18) and .032 interior Quaker Bronze, White or Clear Anodized aluminum. Overall thickness of panel shall be 3".
 - 5 CEILING: Interior ceiling shall be a panel system providing smooth flat interior, constructed from 20ga pre-finished white steel with polyisocyanurate insulation (R-6.5) above.
 - 6 ROOF: Roof shall be constructed using galvanized 20ga, G-60 interlocking pan sections. Sections shall be 3" high with varying widths. Roof shall drain into full perimeter gutter system.
 - 7 WINDOWS: Fixed windows shall be single pane 1/4" clear tempered safety glass. Glass shall be glazed within wall system extrusions and not fastened to exterior wall. Glass sealed with concealed gasket system. (Qty-1) Sliding window shall have aluminum frame and single pane 1/4" clear tempered safety glass, insect screen and locking device. Slide window frame color to match building finish.
 - 8 DOOR: (Qty-1) Sliding door shall be extruded aluminum frame, half glass (1/4" clear tempered safety glass), top hung style using an overhead track and heavy duty ball bearing nylon tires with steel hub. Door shall be supplied with mortise hook bolt lock set with removable core type cylinder compatible with Best core exterior and interior thumb turn, heavy duty pull handles, and aluminum threshold (steel threshold not acceptable). Door color shall be Quaker Bronze, White or Clear Anodized.
 - 9 ELECTRICAL: Building shall be wired according to N.E.C. standards. Load center shall be 125 amp main lug, 120/240 volt unit with 6/12 open circuits. Wiring shall be within surface mounted EMT conduit, and included shall be (Qty-1) GFI duplex receptacle with tester and (Qty-1) receptacle shall be installed for a 115V air conditioner.
 - 10 LIGHTING: Lighting shall be a (Qty-1) 4' LED light with wall mounted switch near door.
 - 11 HEATER: Heater shall be a wall mount electric unit with fan forced operation, 1500w /5120 BTU, 120V and thermostat in an enamel coated 20 gauge steel cabinet.
 - 12 AC UNIT: Air Conditioner shall be a thru-wall unit, 8000 cooling Btu, 115V, 24-hour timer, remote controlled, 3-cooling and fan-only speeds, plus auto fan, 8-way air flow control and auto-restart saves settings if power is interrupted.
 - 13 COUNTER: Full width by 24" deep by 3/4" white melamine work space counter supplied with counter top drop wire grommet(s).
 - 14 FOUNDATION: Foundation is by others in the field. Recommended concrete pad size is 12" minimum larger than building in both length and width dimensions. Pad must be level. Building is to be anchored to pad using 1/2" diameter minimum anchor bolt (by others), QTY-1 per anchor clip.



Twin Modular Services Inc.
 1001 Lower Landing Rd. Ste 607
 Blackwood, NJ 08012
 PHONE: 856-227-0057
 e-mail: info@guardboothonline.com
 www.guardboothonline.com

Notice - Twin Modular Services Inc. claims proprietary rights in the information disclosed on this drawing. It is issued in confidence for engineering information only and may not be used, in whole or in part, to manufacture anything whether or not shown hereon, reproduced or disclosed to anyone without direct written permission from Twin Modular Services Inc.

TITLE:	7'-9" X 12'-0" ALUMINUM BUILDING
JOB NO:	-
QUOTE NO:	-
LOCATION:	T.B.D.
MOD NO:	812GBALSD
COLOR:	SEE SPECIFICATIONS
DATE:	11.30.22
DRAWN BY:	CDA
SCALE:	N.T.S.
SHEET:	1 OF 3

REVISION STATUS OF SHEETS			
-	-	-	REV
3	2	1	SH
CERTIFICATION			

CUSTOMER APPROVAL

THESE DRAWINGS AND SPECIFICATIONS HAVE BEEN PRODUCED IN ACCORDANCE WITH TWIN MODULAR SERVICES INC. PROPOSAL AND THE PROJECT DESIGN. THE PROJECT WILL BE MANUFACTURED IN ACCORDANCE TO THIS INFORMATION AS SUBMITTED. THE SECURING OF BUILDING PERMITS AND COMPLIANCE WITH APPROPRIATE BUILDING CODES IS THE RESPONSIBILITY OF THE PURCHASER OF THE BUILDING AND NOT THE RESPONSIBILITY OF TWIN MODULAR SERVICES

- APPROVED AS SUBMITTED
- APPROVED AS NOTED
- REVISE AND RESUBMIT

SIGNED: _____ DATE: _____

ELEVATION A

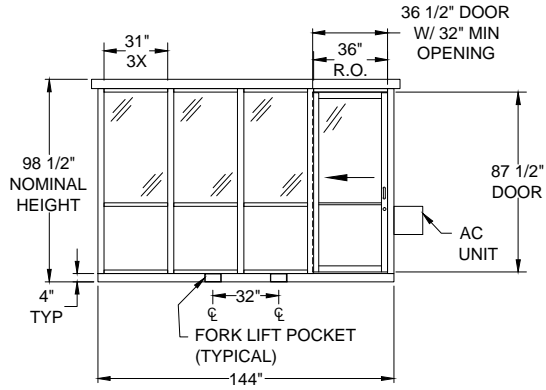

ELEVATION C

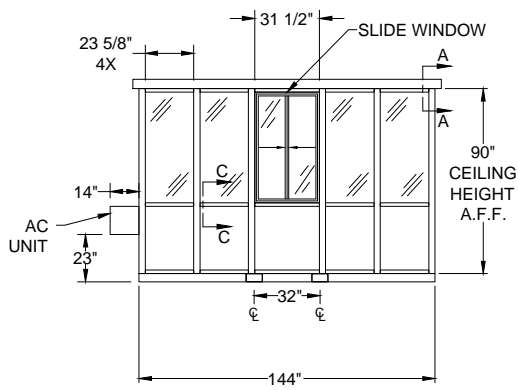

ELEVATION B

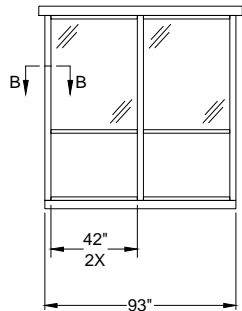

ELEVATION D

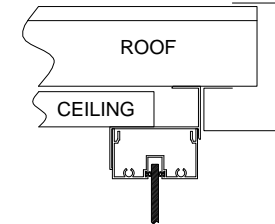
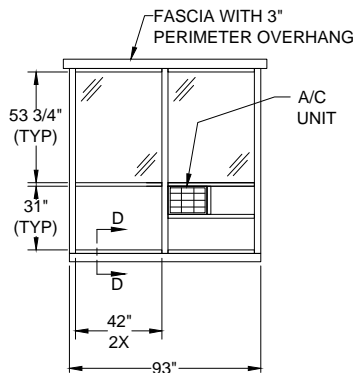

SECTION A-A
SCALE: N.T.S.

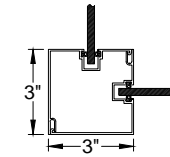

SECTION B-B
SCALE: N.T.S.

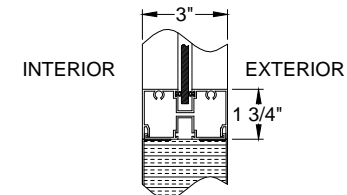

SECTION C-C
SCALE: N.T.S.

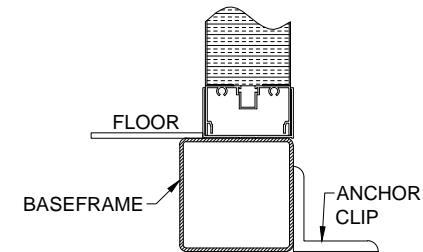

SECTION D-D
SCALE: N.T.S.



Twin Modular Services Inc.
1001 Lower Landing Rd. Ste 607
Blackwood, NJ 08012
PHONE: 856-227-0057
e-mail: info@guardboothonline.com
www.guardboothonline.com

Notice - Twin Modular Services Inc. claims proprietary rights in the information disclosed on this drawing. It is issued in confidence for engineering information only and may not be used, in whole or in part, to manufacture anything whether or not shown hereon, reproduced or disclosed to anyone without direct written permission from Twin Modular Services Inc.

TITLE:	7'-9" X 12'-0" ALUMINUM BUILDING
JOB NO:	-
QUOTE NO:	-
LOCATION:	T.B.D.
MOD NO:	812GBALSD
COLOR:	SEE SPECIFICATIONS
DATE:	11.30.22
DRAWN BY:	CDA
SCALE:	N.T.S.
SHEET:	2 OF 3

CUSTOMER APPROVAL

THESE DRAWINGS AND SPECIFICATIONS HAVE BEEN PRODUCED IN ACCORDANCE WITH TWIN MODULAR SERVICES INC. PROPOSAL AND THE PROJECT DESIGN. THE PROJECT WILL BE MANUFACTURED IN ACCORDANCE TO THIS INFORMATION AS SUBMITTED. THE SECURING OF BUILDING PERMITS AND COMPLIANCE WITH APPROPRIATE BUILDING CODES IS THE RESPONSIBILITY OF THE PURCHASER OF THE BUILDING AND NOT THE RESPONSIBILITY OF TWIN MODULAR SERVICES

- APPROVED AS SUBMITTED
- APPROVED AS NOTED
- REVISE AND RESUBMIT

SIGNED: _____ DATE: _____

CERTIFICATION

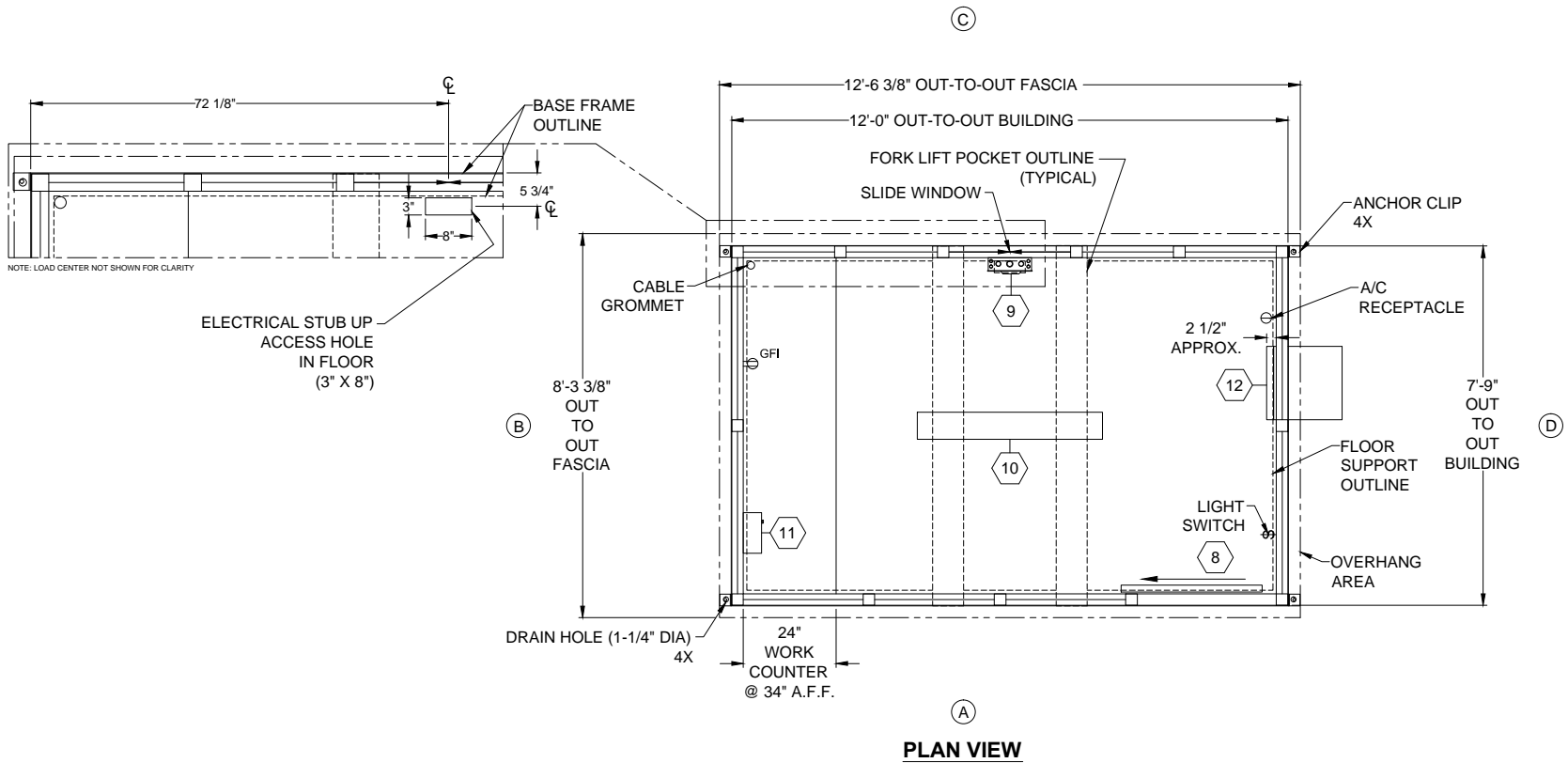

Twin Modular Services Inc.
 1001 Lower Landing Rd. Ste 607
 Blackwood, NJ 08012
 PHONE: 856-227-0057
 e-mail: info@guardboothonline.com
 www.guardboothonline.com

Notice - Twin Modular Services Inc. claims proprietary rights in the information disclosed on this drawing. It is issued in confidence for engineering information only and may not be used, in whole or in part, to manufacture anything whether or not shown hereon, reproduced or disclosed to anyone without direct written permission from Twin Modular Services Inc.

TITLE:	7'-9" X 12'-0" ALUMINUM BUILDING
JOB NO:	-
QUOTE NO:	-
LOCATION:	T.B.D.
MOD NO:	812GBALSD
COLOR:	SEE SPECIFICATIONS
DATE:	11.30.22
DRAWN BY:	CDA
SCALE:	N.T.S.
SHEET:	3 OF 3

CUSTOMER APPROVAL

THESE DRAWINGS AND SPECIFICATIONS HAVE BEEN PRODUCED IN ACCORDANCE WITH TWIN MODULAR SERVICES INC. PROPOSAL AND THE PROJECT DESIGN. THE PROJECT WILL BE MANUFACTURED IN ACCORDANCE TO THIS INFORMATION AS SUBMITTED. THE SECURING OF BUILDING PERMITS AND COMPLIANCE WITH APPROPRIATE BUILDING CODES IS THE RESPONSIBILITY OF THE PURCHASER OF THE BUILDING AND NOT THE RESPONSIBILITY OF TWIN MODULAR SERVICES

- APPROVED AS SUBMITTED
- APPROVED AS NOTED
- REVISE AND RESUBMIT

SIGNED: _____ DATE: _____

CERTIFICATION