

GENERAL BUILDING SPECIFICATIONS:

guardboothonline.com
 guardhousesonline.com
 guardshackonline.com

- GENERAL:** Pre-assemble building fabricated from low maintenance, lightweight corrosive resistant aluminum (factory fabricated). Building exterior shall have no exposed fasteners.
- 1 DIMENSIONS:** 4'-0" wide x 6'-0" long and 98 1/2" nominal outside height. Interior dimension from floor to ceiling shall be 90".
 - 2 FRAME CONSTRUCTION:** Provide structural framing of 6063-T6 aluminum alloy extrusions. Members shall have a QUAKER BRONZE or White finish. Connections shall be fastened internally to framing system using mechanical fasteners or MIG welded where necessary. Exposed fasteners on framing system are not acceptable.
 - 3 BASE/FLOOR:** Floor structure shall be 1/8" aluminum anti-slip finished floor.
 - 4 LOWER WALL PANEL:** Exterior shall be .032 QUAKER BRONZE aluminum, 2 3/4" THERMAX insulation (R-18) and .032 interior aluminum. Overall thickness of panel shall be 3" .
 - 5 CEILING/ROOF:** Constructed using Hardboard- Factory coated FRP with white finish exterior and interior. Roof drains into full perimeter gutter system.
 - 6 WINDOWS:** Fixed windows shall be single pane 1/4" clear tempered safety glass. Sliding window shall have aluminum frame (QUAKER BRONZE) and 1/4" clear tempered safety glass, insect screen, and locking device. Glass shall be glazed within wall system extrusions and not fastened to exterior wall. Glass sealed with concealed gasket system.
 - 7 DOOR:** Sliding door shall be extruded aluminum frame, half glass, top hung style using an overhead track and heavy duty ball bearing nylon tires with steel hub. Door shall be supplied with mortise hook bolt lockset with removable cylinder. Door color shall be QUAKER BRONZE.
 - 8 ELECTRICAL:** Building shall be wired according to N.E.C. standards. Load center shall be a 125 amp main lug, 120/240 unit with 8/16 open circuits. Wiring shall be within surface mounted EMT conduit, and included shall be (qty-1) GFI duplex receptacle with tester.
 - 9 LIGHTING:** Lighting shall be a dual bulb fluorescent light with pull switch.
 - 10 HEAT/AC:** Heating shall be wall mounted electric with fan forced operation, 1500w/5120 BTU and thermostat in a enamel coated 20 ga, steel cabinet. AC Wall Mounted 6000 BTU with dedicated 110V Receptacle
 - 11 COUNTER:** Full width x 24" deep x 3/4" thick white melamine work counter with (qty-1) cable grommet.

Bronze

White



SIGNED: _____
 DATE: _____

Twin Modular Services Inc.
 1001 Lower Landing Rd. ~Ste 607
 Blackwood, NJ. 08012



Twin Modular Services Inc.
 1001 Lower Landing Rd. Ste607
 Blackwood, NJ. 08012
 856-227-0057

e-mail:
 paul@twinmodular.com
 peter@twinmodular.com

guardboothonline.com
 guardhousesonline.com
 guardshackonline.com

RU04UEK	Blackwood, NJ 08012
TU04UEK	46GBALSD
0USUUK	07/16/22
00EY P0YK	JWL
00EYK	1

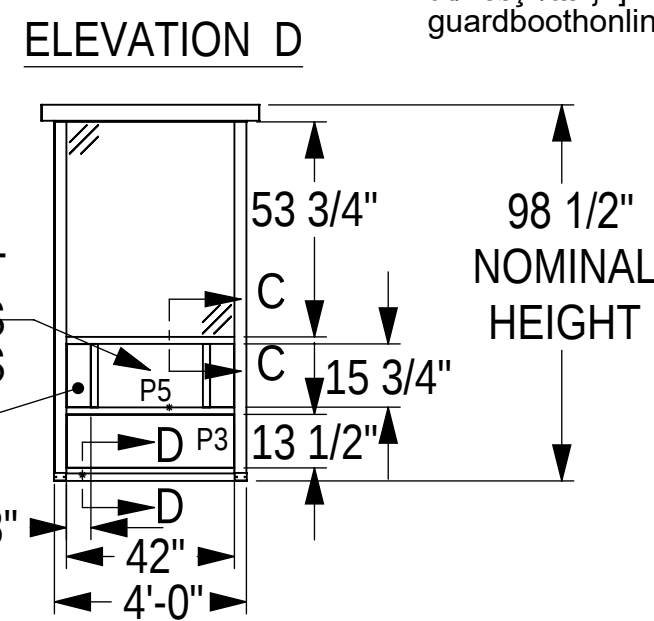
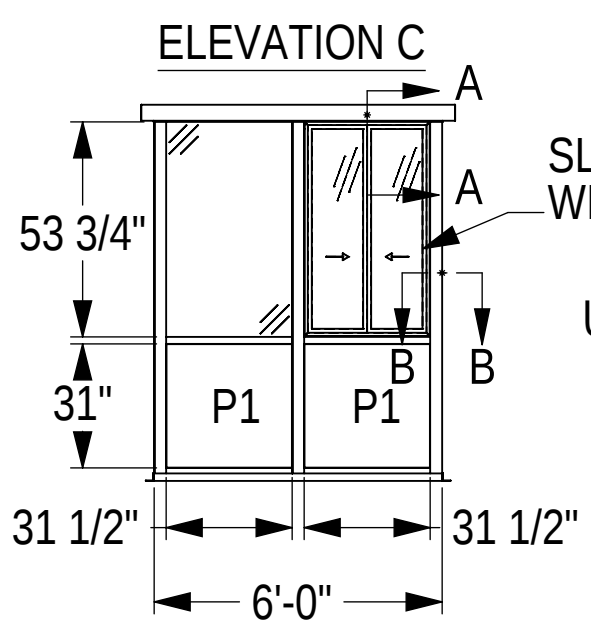
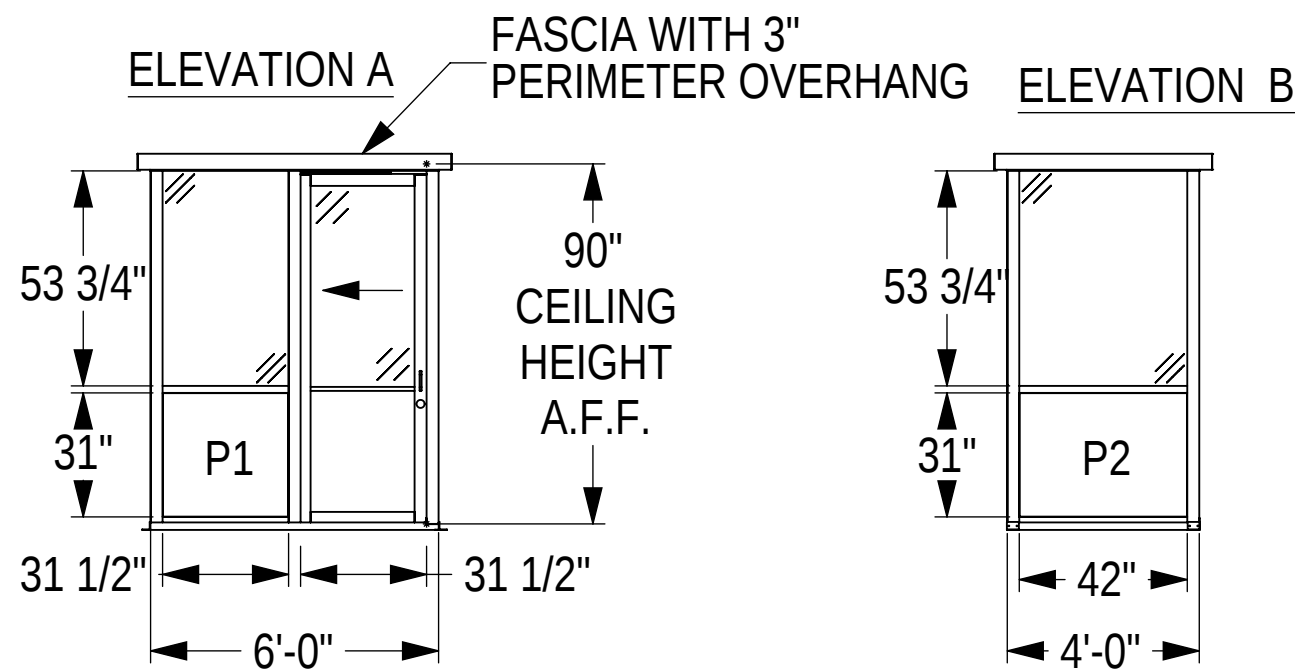

guardboothonline.com
 guardboothonline.com

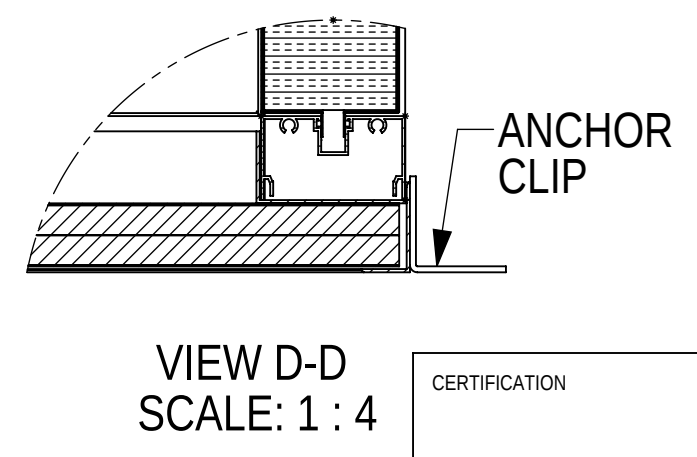
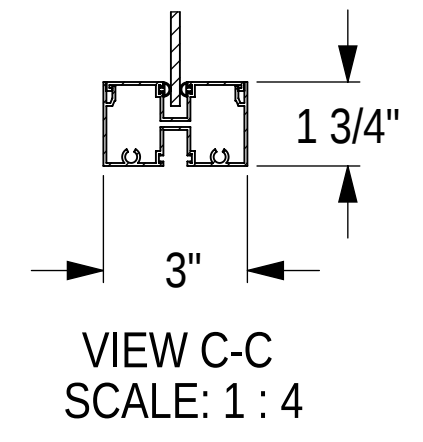
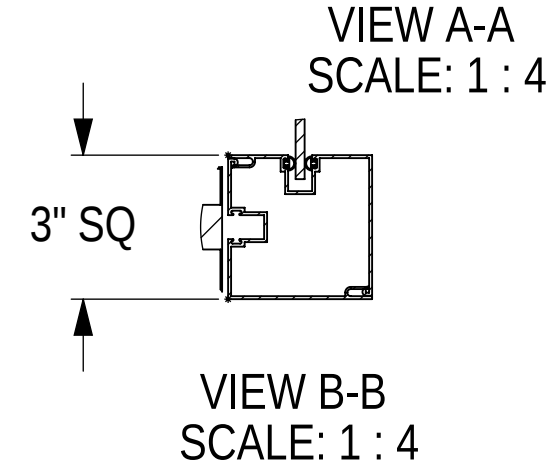
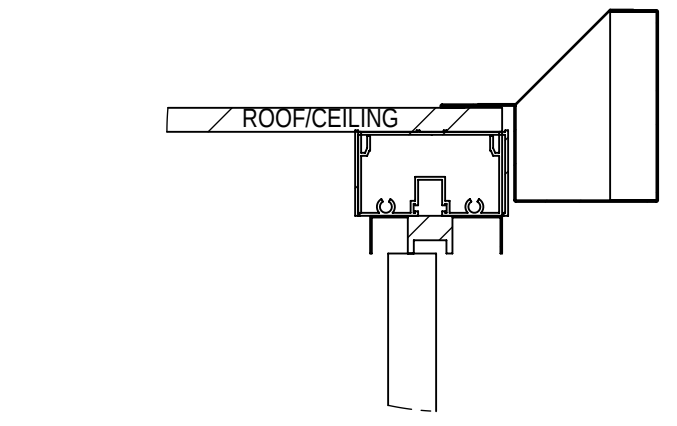
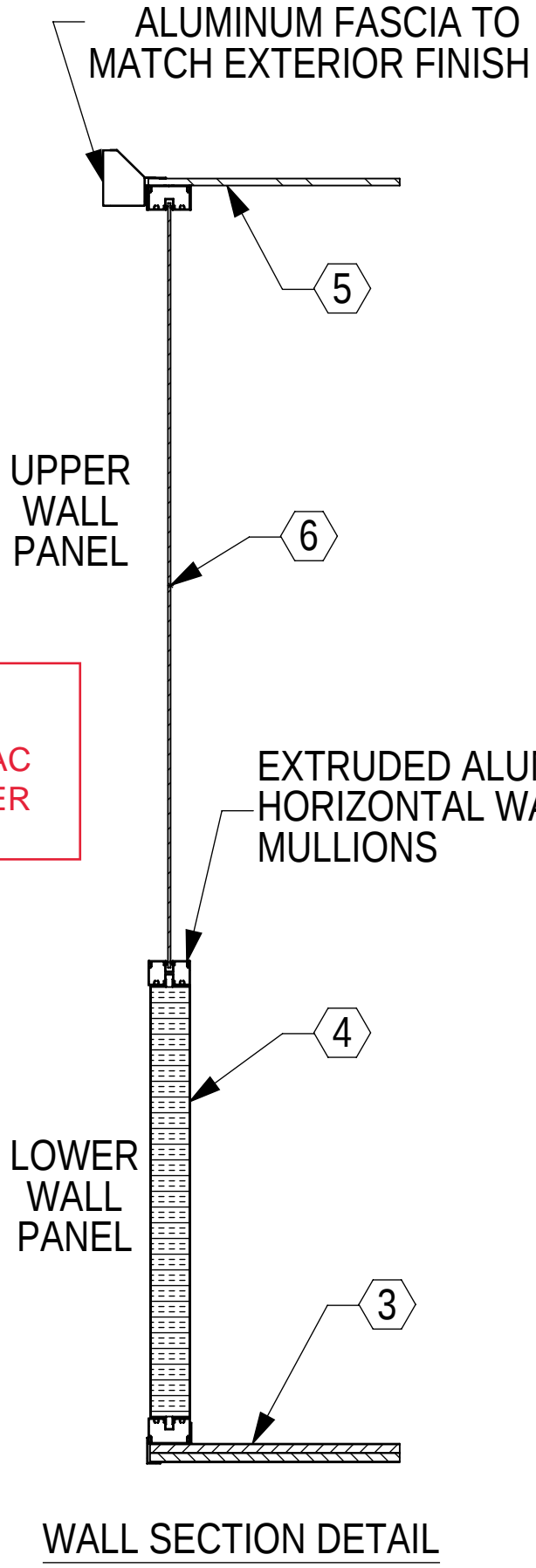
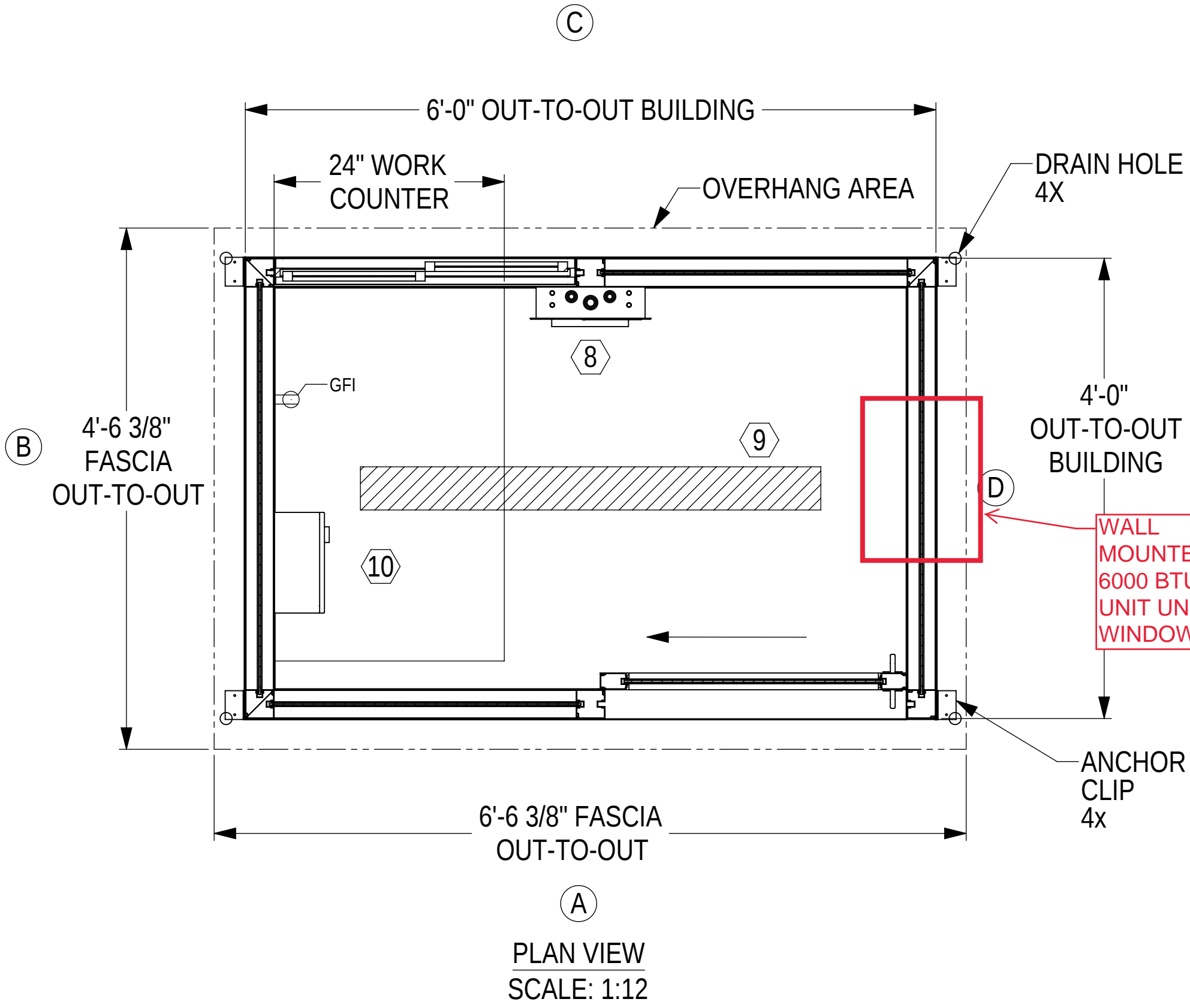

OWUVUT OUAUUXOS
 SIGNED: _____
 DATE: _____

1/4" CLEAR TEMPERED SAFETY GLASS
 2@ 54 3/4" X 32 1/2"
 2@ 54 3/4" X 43"
 1@ 51" X 27" (SLIDE DOOR)
 2@ 49 1/8" X 14 5/16" (SLIDE WINDOW)

CERTIFICATION

Twin Modular Services Inc.
 1001 Lower Landing Rd. Ste 607
 Blackwood, NJ. 08012



Twin Modular Services Inc. 1001 Lower Landing Rd. Ste607 Blackwood, NJ. 08012
 PHONE: 856-227-0057
 e-mail: paul@twinmodular.com peter@twinmodular.com
 WEBSITE: guardboothonline.com guardhousesonline.com guardshackonline.com

VOISOK	I O A A A A
RUOPUEK	07 { a } { 10 } qaa *
SUOCBQPK	Blackwood, NJ. 08012
TUOPUEK	46GBALSD
OUSUUK	UWOSOUUUPZO
OCBOK	07/16/22
OUCE PBOYK	JWL
CEUUXOXOAOYK	
UOCBOK	PUPO
UPOONK	2

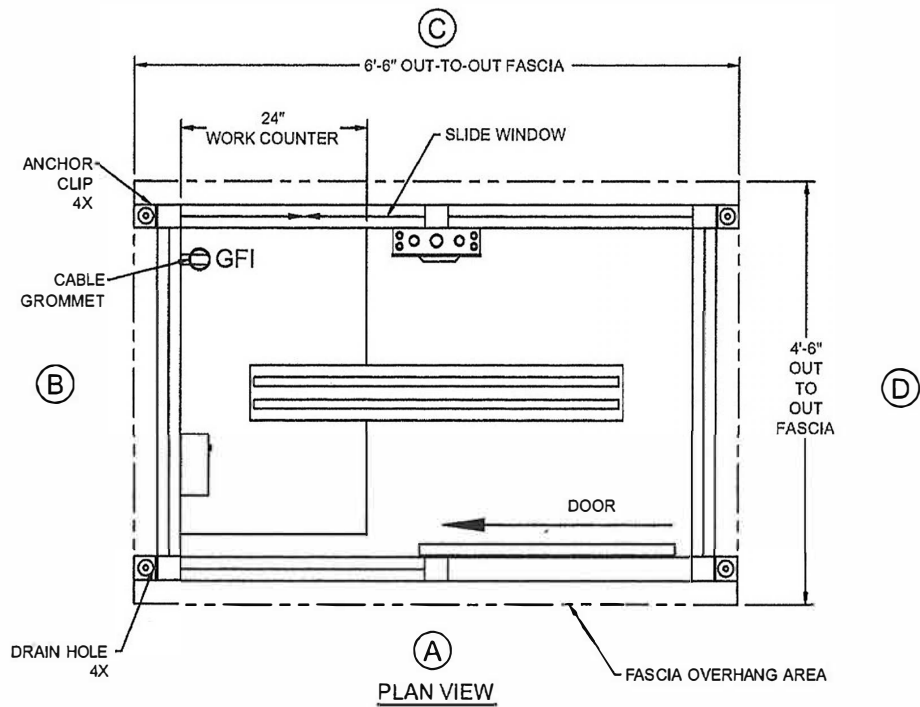
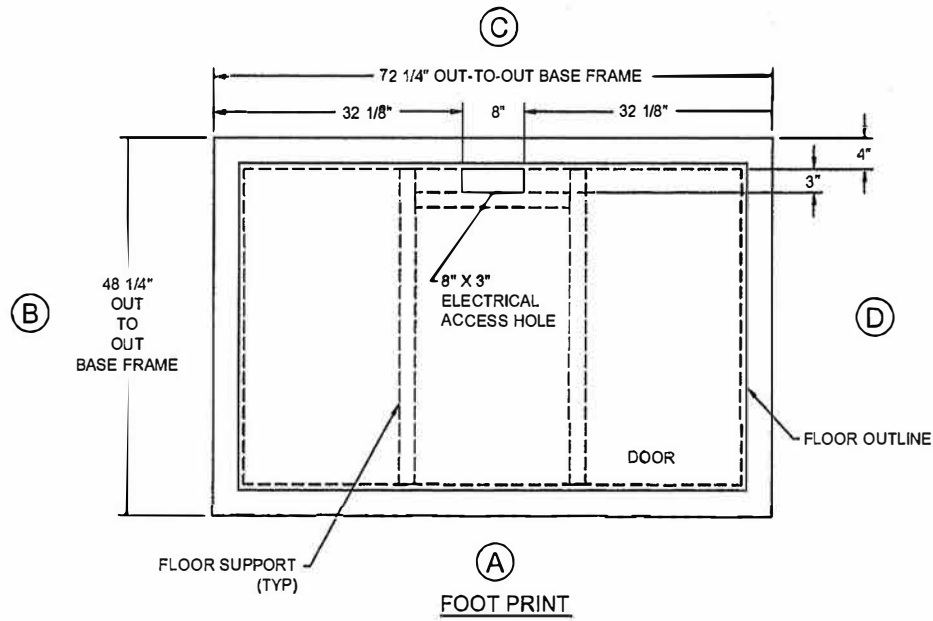

46GBALSD
(ELECTRICAL ACCESS HOLE)



TWIN MODULAR SERVICES INC.

Twin Modular Services Inc.
1001 Lower Landing Rd. Ste #607
Blackwood, N.J. 08012-3122

Phone: 856-227-0057

WEBSITE:
www.guardboothonline.com

E-mail: paul@twinmodular.com

Notice - Twin Modular Services Inc. claims proprietary rights in the information disclosed on this drawing. It is issued in confidence for engineering information only and may not be used, in whole or in part, to manufacture anything whether or not shown hereon, reproduced or disclosed to anyone without direct written permission from Twin Modular Services Inc.

TITLE	4'-0" X 6'-0" ALUMINUM BUILDING
JOB NO	0180283
QUOTE NO	
LOCATION	
MOD NO:	46GBALSD
COLOR:	SEE SPECIFICATIONS
DATE	10.04.18
DRAWN BY	CDA
SCALE	1/8" = 1'
SHEET	1 OF 1

CERTIFICATION