

# GENERAL SHELTER SPECIFICATIONS: QTY - 1 SHELTER

- A. GENERAL: Unassembled modular shelter is fabricated from low maintenance, lightweight corrosive resistant aluminum (factory fabricated). Site assembly required.
- 1 DIMENSIONS: 5'-0" wide x 10'-0" long, 87 1/2" nominal exterior height and 83" interior ceiling height.
- 2 FRAME: Provide structural framing of 6063-T6 aluminum alloy extrusions with Quaker Bronze finish. Framing assembled using internally located mechanical fasteners. Exposed fasteners on framing system are not acceptable. Standard 7 3/4" ventilation space at bottom of unit.
- 3 ROOF/CEILING: Roof shall be constructed using galvanized 20 gauge, G-60 interlocking pan sections. Sections are 3" high varying widths. Roof drains into full perimeter gutter system with drain holes. Interior ceiling shall be a panel system providing smooth flat interior, constructed from 20 gauge prefinished white steel able to support optional lighting or heating fixtures.
- 4 WINDOWS: Fixed windows are single pane 1/4" minimum clear tempered safety glass, glazed within wall system extrusions and not fastened to exterior wall. Glass sealed with concealed gasket system.
- 5 ANCHORING: Shelter installation requires concrete pad to be 12" minimum larger than shelter in both length and width dimensions. Pad must be level within 1/2" over length and width of structure. Shelter to be anchored to pad using height adjustable aluminum shoe and anchored down using 1/4" X 1 7/8" Hilti Kwik Hus-EZ screw anchors. Concrete pad by others in the field.

INSTALLATION: Unit is knocked down and crated, off loaded and installed by others.

TWIN MODULAR SERVICES INC  
 1001 LOWER LANDING ROAD STE 607  
 BLACKWOOD, NJ 08012



Twin Modular Services Inc.  
 1001 Lower Landing Rd. Ste 607  
 Blackwood, NJ. 08012  
 Ph: 856-227-0057  
 e-mail: info@guardboothonline.com  
 www.guardboothonline.com

Notice - Twin Modular Services Inc. claims proprietary rights in the information disclosed on this drawing. It is issued in confidence for engineering information only and may not be used, in whole or in part, to manufacture anything whether or not shown hereon, reproduced or disclosed to anyone without direct written permission from Twin Modular Services Inc.

TITLE:	5'-0" X 10'-0" ALUMINUM SHELTER
JOB NO:	-
QUOTE NO:	0200277
LOCATION:	-
MOD NO:	TALS510F1-R
COLOR:	SEE SPECIFICATIONS
DATE:	02.18.20
DRAWN BY:	TMK
SCALE:	N.T.S.
SHEET:	1 OF 2

## CUSTOMER APPROVAL

THESE DRAWINGS AND SPECIFICATIONS HAVE BEEN PRODUCED IN ACCORDANCE WITH TWIN MODULAR SERVICES INC. PROPOSAL AND THE PROJECT DESIGN. THE PROJECT WILL BE MANUFACTURED IN ACCORDANCE TO THIS INFORMATION AS SUBMITTED. THE SECURING OF BUILDING PERMITS AND COMPLIANCE WITH APPROPRIATE BUILDING CODES IS THE RESPONSIBILITY OF THE PURCHASER OF THE BUILDING AND NOT THE RESPONSIBILITY OF TWIN MODULAR SERVICES INC.

- APPROVED AS SUBMITTED
- APPROVED AS NOTED
- REVISE AND RESUBMIT

SIGNED: \_\_\_\_\_ DATE: \_\_\_\_\_

CERTIFICATION

TWIN MODULAR SERVICES INC  
 1001 LOWER LANDING ROAD STE 607  
 BLACKWOOD, NJ 08012



Twin Modular Services Inc.  
 1001 Lower Landing Rd. Ste 607  
 Blackwood, NJ. 08012  
 Ph: 856-227-0057  
 e-mail: info@guardboothonline.com  
 www.guardboothonline.com

Notice - Twin Modular Services Inc. claims proprietary rights in the information disclosed on this drawing. It is issued in confidence for engineering information only and may not be used, in whole or in part, to manufacture anything whether or not shown hereon, reproduced or disclosed to anyone without direct written permission from Twin Modular Services Inc.

TITLE:	5'-0" X 10'-0" ALUMINUM SHELTER
JOB NO:	-
QUOTE NO:	0200277
LOCATION:	-
MOD NO:	TALS510F1-R
COLOR:	SEE SPECIFICATIONS
DATE:	02.18.20
DRAWN BY:	TMK
SCALE:	N.T.S.
SHEET:	2 OF 2

**ELEVATION A**

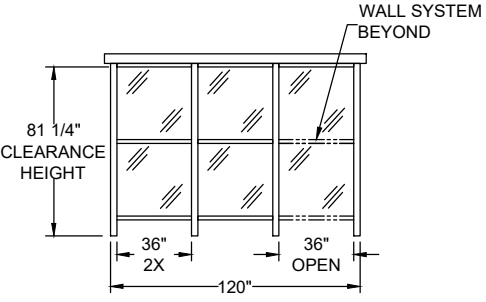

**ELEVATION B & D**

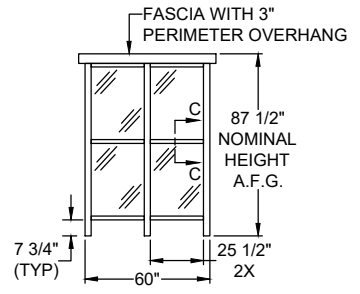

**ELEVATION C**

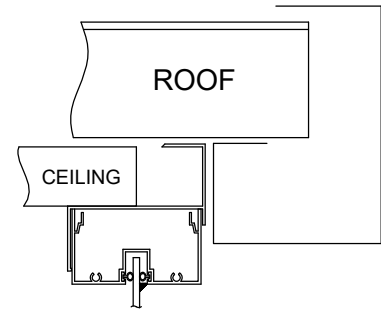
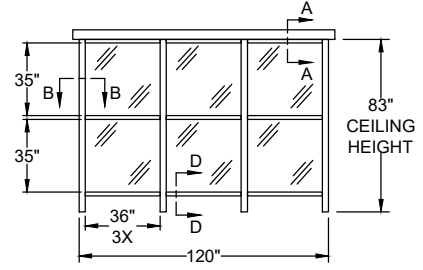

**VIEW A-A**

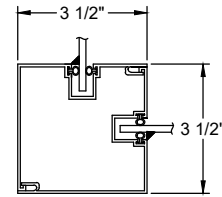

**VIEW B-B**

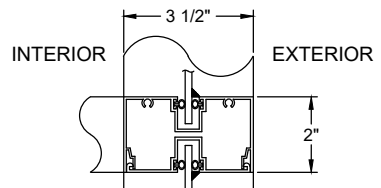

**VIEW C-C**

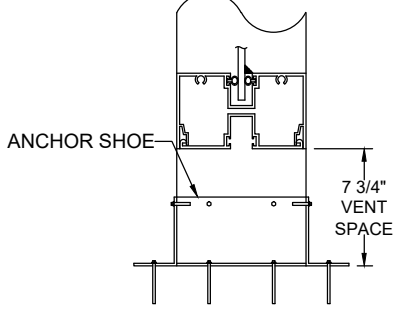

**VIEW D-D**

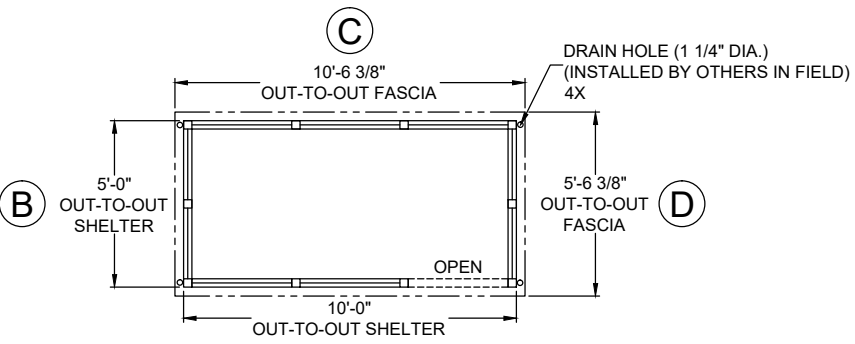

**PLAN VIEW**

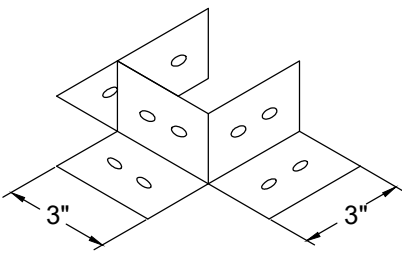

**ANCHOR SHOE**

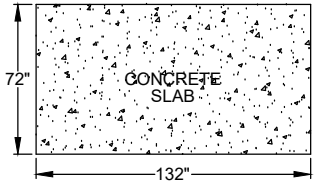

NOTE: CONCRETE SLAB DESIGN BY OTHERS-DIMENSIONS SHOWN ARE RECOMMENDED MIN. SIZES ONLY

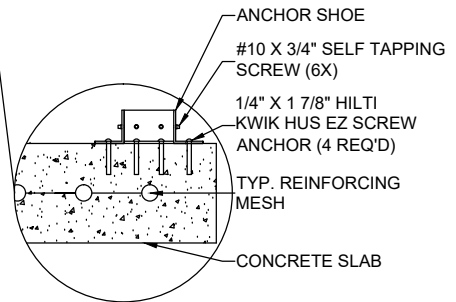

**ANCHORING DETAIL**

**CUSTOMER APPROVAL**

THESE DRAWINGS AND SPECIFICATIONS HAVE BEEN PRODUCED IN ACCORDANCE WITH TWIN MODULAR SERVICES INC. PROPOSAL AND THE PROJECT DESIGN. THE PROJECT WILL BE MANUFACTURED IN ACCORDANCE TO THIS INFORMATION AS SUBMITTED. THE SECURING OF BUILDING PERMITS AND COMPLIANCE WITH APPROPRIATE BUILDING CODES IS THE RESPONSIBILITY OF THE PURCHASER OF THE BUILDING AND NOT THE RESPONSIBILITY OF TWIN MODULAR SERVICES INC.

APPROVED AS SUBMITTED  
 APPROVED AS NOTED  
 REVISE AND RESUBMIT

SIGNED: \_\_\_\_\_ DATE: \_\_\_\_\_

CERTIFICATION